

BUTLER

Assembly Instructions
Style Number 1576

SPECIALTY COMPANY
8200 SOUTH CHICAGO AVE., CHICAGO, IL 60617

PACKAGED

- | | |
|---|------------------|
| (A) 8 -Bolts $\varnothing 1/4'' \times 2''$ | (D) 1 -Table Top |
| (B) 8 -Spring Washer | (E) 4 -Legs |
| (C) 8 -Washer | |

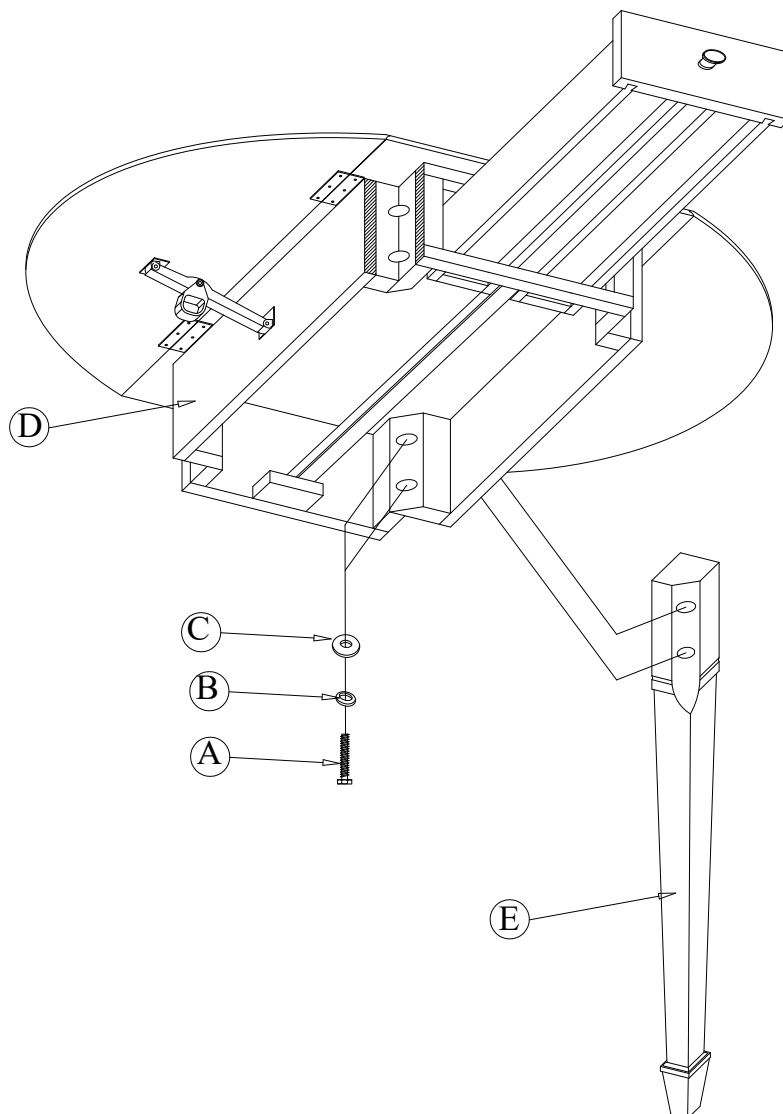

(* **Caution: DO NOT OVERTIGHTEN.**

In any correspondence regarding this product, please include the complete Butler identification number located on the underside of the product.

We hope this Table will be a useful and decorative addition to your home for years to come.

Copyright © Butler Specialty Company, 10/07